

SECTION A-A

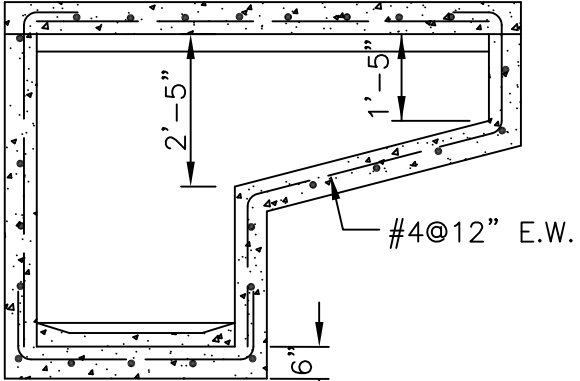

SECTION B-B

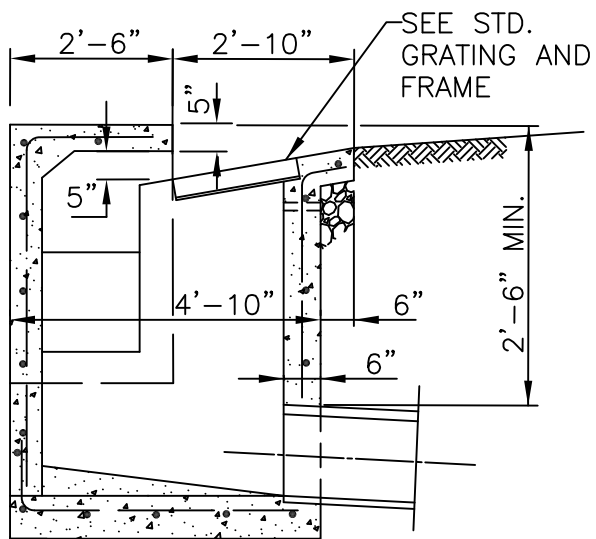

SECTION C-C

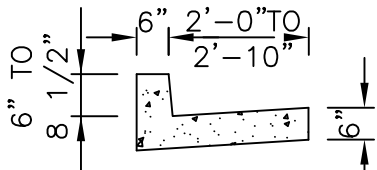

SECTION D-D

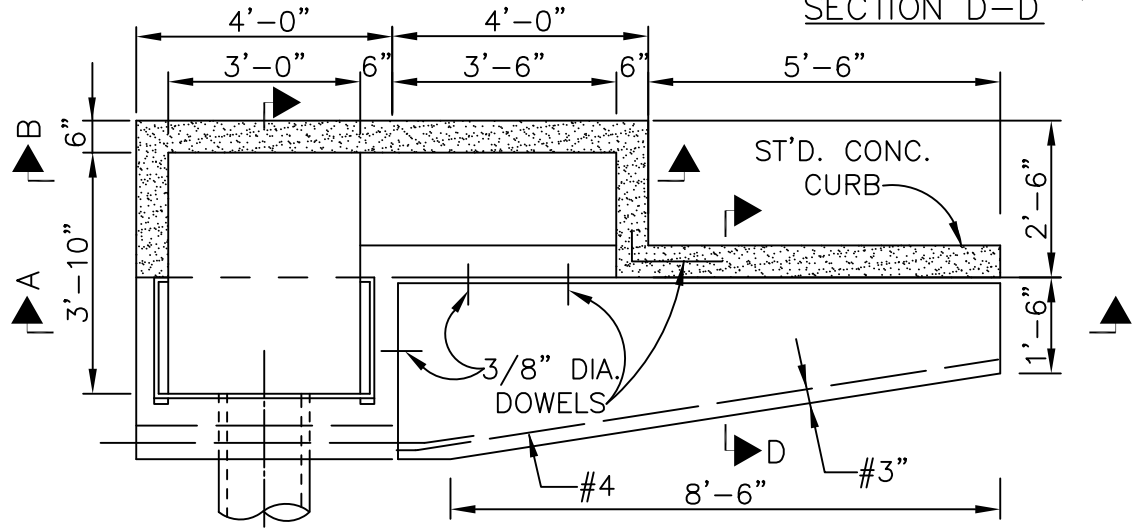

**NOTE:**  
ALL CONCRETE CLASS A.



|   |                  |                             |  |
|---|------------------|-----------------------------|--|
| TITLE   |                  | CATCH BASIN TYPE 1          |  |
| ADOPTED BY CITY COUNCIL DATE:   | SCALE: NONE      | STANDARD DETAIL<br><b>6</b> |  |
| 12/07/2011  | DATE: 11/18/2011 |                             |  |
|   | CHK: JMP         |                             |  |
| 26379 FREMONT ROAD, LOS ALTOS HILLS, CA 94022 • Phone: (650) 941-7222 |                  |                             |  |